

Touchscreen tablet



Description

Portable terminal in tablet form with a large 10 inch touchscreen, allowing for regular data entry from stationary devices (computer, terminal, etc.)

This touchscreen tablet is designed according to the MIL-STD-810x military standard (application temperature from -20 to + 50 °C, with shock and vibration resistance).

Strong & sturdy (resistant to 1.5 meter falls), Waterproof rating of IP 65 (can be used in the rain).

The vast majority of industrial needs can be satisfied by this tablet's many options and accessories, including a bar code scanner, RFID technology access to GSM/3 G networks...

Operating interface :

- 10" backlit color LCD touchscreen
- 6 programmable command keys
- 2 dedicated keys (On/Off, command key block)

Electrical input of 12 volts (with power pack).

Characteristics

CARACTERISTIQUES GENERALES

CPU	Dual-Core Processor 1.6 GHz
Mass Storage	2 Go SSD Disk
RAM	2Go
Screen size	Resistant touchscreen (10.4" - 350 nits)
Resolution	1024 x 768
Communication	WiFi 802.11 a/b/g/n and Bluetooth 4.0
RFID (option)	ISO/IEC 14443A, 14443B Mifare 1K/4K, Ultralight
Webcam	2 Mega-pixel camera with audio input (front side) 5 Mega-pixel camera with LED lighting (back side)
Communication Ports	2 USB 2.0 ports (type A) 1 Audio output (headphone and microphone) 1 Ethernet port (1x10/100 Mbps) via USB micro connector
Dimensions (mm)	275.4 L x 203.6 H x 26.5 P
Waterproof level	IP65
Application temperature	-20°C / +50°C
Humidity	5-95% without condensation
Electrical current	Built-in battery Smart Lithium Polymer, 3 800mAH External power pack 230VAC/19VDC

Plan/Size

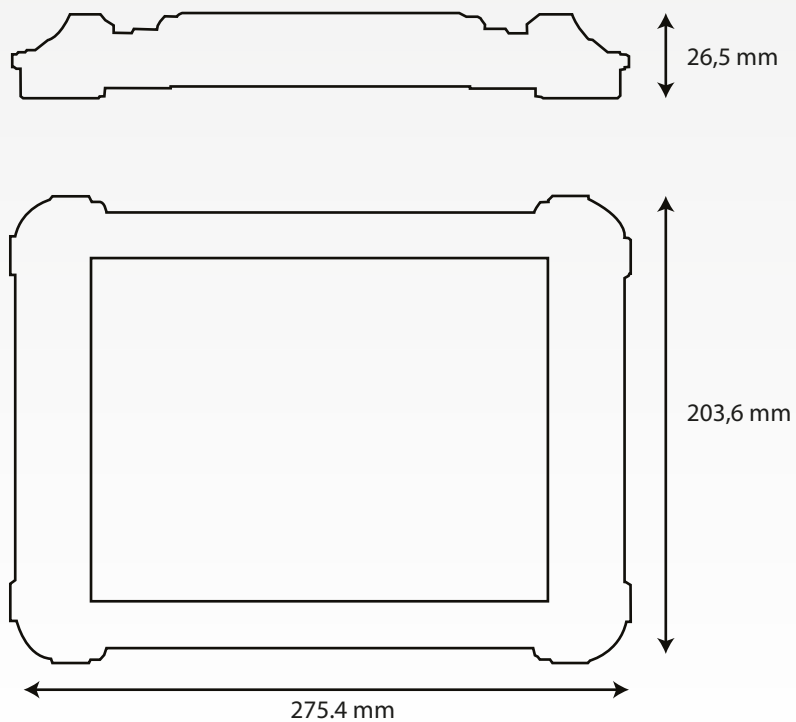

Dimensions in mm

Example of configuration

RP75HL Remote Weight Display

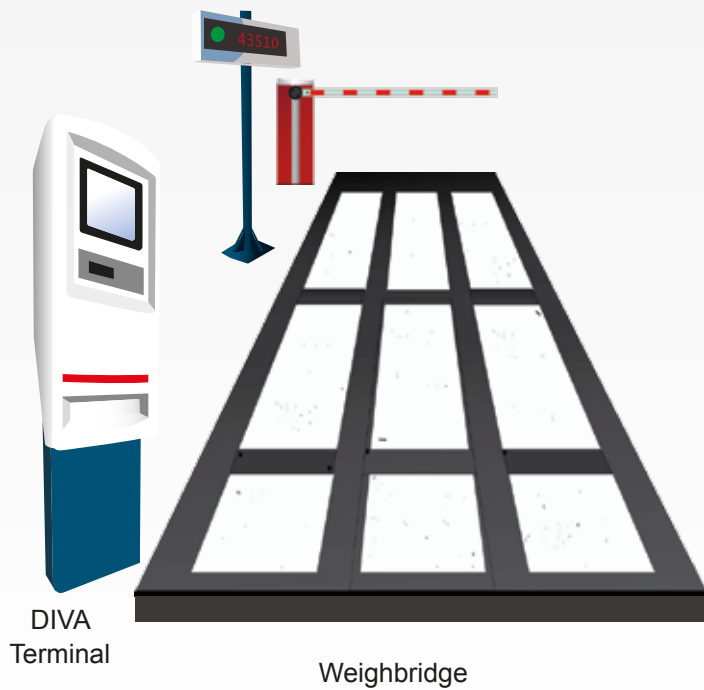

Touchscreen tablet



Features

Depending on the desired application, there are different touchscreens that all allow for a simple and user-friendly experience. Information displayed on the screen is customised to each step of data entry.

Examples below show screens with the weighbridge management software Winstar.



Options/accessories

Options

Office kit:

- 4 USB ports
- 1 VGA
- 1 Ethernet port
- 1 electrical input (230 VAC /19 VDC)



Car mount kit:

- 2 RS 232
- 4 USB ports
- 1 Ethernet port
- 1 electrical input (9-32 VDC)
- Tamper-proof locking system
- VESA mount interface



Bar code scanner



GPS



Second external battery (4200 mAh)



Battery charger



Accessories

Wrist Strap



Shoulder Strap



ARPEGE **MASTERK**

Bâtiment n°6 - 15, rue du Dauphiné
CS 40216 - 69808 St PRIEST - FRANCE
Tél : +33 (0)4 72 22 92 22
Fax : +33 (0)4 72 22 93 45
marketing@masterk.com

Company Registration: 971 506 480 RCS LYON
SIC registration code: APE 2829A French VAT: FR 28 971 506 480

Our product factsheets
are available for download
at our website
www.masterk.com

Your contact information